



Design, analysis, and development of transmission system for an all-terrain vehicle

Priyank Chauhan¹, Ankur Tiwari², Rishabh Singh³, Sunil Kumar⁴, V. K. Saini⁵

^{1,2,3}Student, IMS Engineering College, Ghaziabad, Uttar Pradesh

⁴Assistant Professor, IMS Engineering College, Ghaziabad, Uttar Pradesh

⁵Professor, IMS Engineering College, Ghaziabad, Uttar Pradesh

ABSTRACT

To design an all-terrain vehicle, it is required that the transmission system should withstand all the hurdles on the terrain. The terrain includes the mudpool, rock crawl, dunes etc. The main aim of the transmission system is to provide required torque and power that is being generated by engine to the wheels as per cockpit sitting driver requirement. This include economically simplifying the design of transmission system without compromising the performance and safety standards. This motion comprises of material selection, material procurement, gearbox designing, gearbox manufacturing, Finite Element Analysis (FEA) and simulation test to check for the failure. Since All-terrain vehicle is prone to uneven road conditions and harsh environment due to which a concept of constant and continuous power transmission should be embedded in its design. For which a continuous variable transmission (CVT) i.e. pulley and belt system and designed gearbox work hand in hand to obtain the desired reduction ratio. For designing a transmission system tractive effort, gradability, vehicle resistance, and vehicle maximum speed is to be calculated. With the above-calculated data, the required reduction ratio is calculated. Finite Element Analysis (FEA) is done for the validation of the design.

Keywords: Transmission system, gearbox, Tractive Effort, Gradability, Vehicle resistance, CVT, FEA, ATV.

1. INTRODUCTION

According to V.A.W Hillier & David R. Rogers [1], "Any vehicle equipped with a combustion engine as its prime mover requires a transmission system to transmit torque at an appropriate speed to the driving wheels". Transmission System of a vehicle is the one which transfers power from the stationary Engine to the driving wheels of the vehicle. Power produced by the engine is used differently according to the different load implications on the vehicle. The main task of the installed Transmission system is to use the power produced from engine effectively and provide different speed and torques to the vehicle tires when the load on the vehicle is changing i.e. ranging from the initial overcome of traction to the maximum velocity of the vehicle. Initially, the torque required is high as the vehicle has to overcome the resistances and later when the vehicle is cruising at high speed more and more power is drawn from the engine and hence with a fraction of second change the Transmission system has to adapt itself and has to do multiple duties. The highlights of a good Transmission system are easy connection and disconnection of the Engine from the rest of the driveline, fast acceleration, adequate fuel supply and efficiency, maximum speed of the vehicle at which it is cruising. According to Thomas D. Gillespie [2], "Maximum performance in longitudinal accelerator of a motor vehicle is determined by one of two Limits-Engine power or traction limits on the drive wheels. Which limits prevail may depend on vehicle speed. At low speeds, tyre traction may be the limiting factor, whereas at high speeds engine power may account for the limits". The types of the Transmission system are classified on the operating principle.

a. Multistage reduction system which comprised of fixed gear ratios which are selected by the driver manually or automatically by a mechanical or electrical control system depending upon the vehicle operating status.

b. Continuous variable transmission (CVT) consist of infinite no. of variable gear ratios connected via hydraulic or mechanical means. Conventional automatic transmissions use a set of gears that provide a given number of ratios (or speeds). The transmission shifts gears to provide the most appropriate ratio for a given situation: Lowest gears for starting out, middle gears for acceleration and passing, and higher gears for fuel-efficient cruising. Multistage Transmission System uses fixed geometrical locking defined in the transmission box, whereas in CVT concept of friction locking is used. Since friction locking will be requiring an additional

source of energy hence reducing the overall efficiency of the Transmission box, due to which a coupling of cvt with a two-stage reduction gearbox is done such that highly efficient and optimized geometry can be prepared.

1.1 CONTINUOUSLY VARIABLE TRANSMISSION (CVT)



Fig-1.1: - CV TECH CVT with Primary, Secondary & Belt

A CVT consists of two pulleys and a v-grooved belt driving them. The two pulleys are separately termed as a Primary and Secondary pulley. Here the secondary pulley is directly coupled to the gearbox via a shaft and the Primary pulley is coupled with the engine crankshaft by providing a countershaft so that a proper spacing between them can be done. CV-TECH cvt is used with a reduction ratio of **3:0.43**. Initially, in the idle condition, the primary pulley rotates and secondary pulley remains stationary due to the friction belt and traction force of the vehicle. Now further with the raging speed the weights in the Primary pulley apply centrifugal force and the Primary pulley expands due to which the belt gets tightened up and hence the secondary drum rotates due to which the gears in gearbox rotates and hence the power from engine is delivered to the wheels with the cumulative reduction of gearbox and CVT. Since a step is reduced in delivering power to the wheels due to which overall efficiency of the Transmission system is increased and hence wide range power distribution is possible.

1.2 GEARBOX

A gearbox is a device which consists of Gears and a casing such that in final stage after reduction the power reaches to wheels via propellers being connected to the output shaft. The material is selected for manufacturing of gears according to the driving conditions. Since Power from diesel or petrol reciprocating engine is delivered in the form of Torque and angular speed to the wheels of the propelling vehicle. The aim of the Gearbox is to provide power to the wheels of the vehicle according to the requirement of the driver sitting in the cockpit.

2. VEHICLE DYNAMICS

When a vehicle moves on a certain terrain then the vehicle undergo different dynamics consideration and hence collectively termed as vehicle dynamics. It is very important to take vehicle dynamics in the design consideration because in reality, the vehicle has to face such harsh conditions. If the air drag is neglected at normal speed, then the load on the wheels is the main force acting on the vehicle.

2.1 DESIGN CONSIDERATIONS

- Mass of the vehicle = 213 kg
- Mass of the driver = 70 kg
- Static coefficient of friction (μ_2) = 0.9
- The height of the center of gravity (h) = 50.8 cm
- Wheelbase = 129.54 cm
- Distance of the C.G from the front wheel center (a_1) = 82.55cm
- The distance of the C.G from the rear wheel center (a_2) = 46.99cm
- Tire dimensions (in inches) = 22*7*12 (front) & 23*7*12 (rear)

3. PERFORMANCE CHARACTERISTICS

3.1 VEHICLE RESISTANCE

Vehicle resistance plays a vital role in designing a vehicle. Now, these are the resistances which the vehicle has to overcome to run or to complete the perspective.

Vehicle resistance is made up of [3],

- a. Wheel resistance or Rolling resistance (F_R),
- b. Air resistance (F_L),

- c. Gradient Resistance (F_{St})
- d. Acceleration resistance (F_a)

3.1.1 Wheel Resistance

It comprises of rolling resistance, road surface resistance, and slip resistance. The integral of the pressure distribution over the tire contact area gives the reaction force R and GR is the wheel load. Because of the asymmetrical pressure distribution in the wheel contact area of the rolling wheel, the point of application of the reaction force R is located in front of the wheel axis by the amount of eccentricity e [5].

$$F_R = f_r m_f g \cos \alpha_{St} \tag{3.1}$$

f_r is the dimensionless proportionality factor known as the rolling resistance.

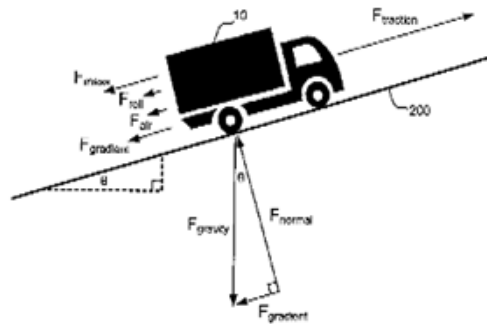

Fig: - 3.1.1 FBD of a moving vehicle

3.1.2 Air Resistance

Air flow occurs around the moving vehicle and through it for purposes of cooling and ventilation. The air resistance is made up of the pressure drag including induced drag (turbulences induced by differences in pressures), surface resistance and internal (through-flow) resistance. Drag is calculated by [3]

$$F_L = \frac{1}{2} \rho_L C_W A v^2 \tag{3.3}$$

Where, ρ is 1.199kg/m³ and C_w (coefficient of drag) is taken as 1.2

3.1.3 Gradient Resistance

The gradient resistance or downhill force relates to the slope descending force and is calculated from the weight acting at the center of gravity.

Fig.3.1.1 Free body diagram of a vehicle on an inclined plane [3]

$$F_{St} = m_F g \sin \alpha_{St} \tag{3.4}$$

3.1.4 Acceleration Resistance

In addition to the driving resistance occurring in steady state motion (v = constant), inertial forces also occur during acceleration and braking. The total mass of the vehicle m_F and the inertial mass of the rotating parts of the drive acceleration or brakes are the factors influencing the resistance to acceleration [3]

$$F_a = \lambda m_F \alpha \tag{3.5}$$

3.1.5 Total Driving Resistance

Total driving resistance F_t is the combination of all the resistances together. Hence the traction required at the wheels of the vehicle is equal to the total driving resistance which the vehicle has to overcome to move out of its idle speed condition.

$$F_t = F_a + F_{St} + F_L + F_R \tag{3.6}$$

4. GEAR RATIO CALCULATION

From the above equations being used, we can infer the result that

$$\begin{aligned}
 F_R &= 247.2 \text{ N} && \text{from equ.3.2} \\
 F_{St} &= 1417.95 \text{ N} && \text{from equ.3.3} \\
 \text{Vehicle velocity, } v &= 3.14 \cdot d \cdot N / 60 \times \\
 &= 110.119/x \\
 F_L &= 2910.286/x^2 && \text{from equ.3.4} \\
 \text{Traction, } F_t &= 19.68 \cdot 0.8x / 0.5342 \\
 &= 53.89x \text{ Nm} \\
 \text{For limiting condition, i.e. } F_a &= 0 \\
 53.899 x^3 &= 1665.16x^2 - 1637.039 && \text{from equ.3.6} \\
 \text{Total gear ratio, } x &= 29.5
 \end{aligned}$$

For CV-tech CVT [9]

$$\begin{aligned}
 \text{Max ratio} &= 3:1 & \text{Min ratio} &= 0.45:1 \\
 \text{Hence,} & & & \\
 \text{Gear box reduction ratio} & & &= 9.35667
 \end{aligned}$$

4.1 Splitting Gear Ratio

According to **Tudose, O. Buiga, D. Jucan, C. Stefanache (2008) [4]**, the optimal design of a two-stage speed reducer has various constraints such as the face width, transmission ratio, and center distance affect the optimal design of any speed reducer. The transmission ratio for the first stage is almost equal to the second stage, in any optimal design solution.

Table-1: Reduction ratio

| | |
|---------------------------------------|------|
| Gear ratio for the first stage (1&2) | 3.1 |
| Gear ratio for the second stage (3&4) | 3.13 |

5. DESIGN OF GEARS

5.1 Material used for gears

For designing gears, the material selection is an important aspect. Following are the properties which should be possessed by the gear material: -

- High Tensile Strength
- To withstand the dynamic load's endurance strength should be high
- Low coefficient of friction
- High manufacturability

Generally, cast iron, steel, brass, and bronze are preferred for manufacturing metallic gears with cut teeth. Commercially cut gears have a pitch line velocity of about 5 meters/second. [5]

$$\begin{aligned}
 \text{Material used} &= 8620 \text{ steel} \\
 S_{ut} = \text{ultimate tensile stress} &= 800 \text{MPa} \\
 S_{yt} = \text{ultimate yield stress} &= 600 \text{MPa} \\
 \text{BHN} &= 300 \\
 \text{Elongation} &= 17\% \\
 \text{Poisson's ratio} &= 0.25 \\
 \text{Bulk modulus} &= 110 \text{GPa}
 \end{aligned}$$

5.2 Assumptions

$$\begin{aligned}
 \text{Module for gear 1\&2} &= 2.5 \\
 \text{Module for gear 3\&4} &= 3
 \end{aligned}$$

5.3 Calculation

For designing if gears are made up of same material then designing should be done according to the pinion gear.

For Gear 1

At high CVT ratio: - 3:1 (hill climb)

Rpm of engine at max torque = 2700 rpm

Gear 1 rpm, $n_{p1} = 2700/3 = 900$ rpm
 Tangential velocity, $v = \pi dN/60 = 2356.196$ m/s

Tangential tooth load, [6,7]

$$W_T = \sigma * C_v * b * p_c * Y \quad (3.7)$$

Where,

$C_v =$ Velocity Factor = 0.718
 $b =$ Face Width = 25
 $p =$ Circular Pitch = 7.3531
 $Y =$ Lewis Form Factor = 0.1084
 $W_T =$ = 4075.29N
 Power = 9.6Kw

Note: - Above value of power is larger than maximum power we are going to transmit which is 7.4kw. Hence the design is safe [7].

For Gear 3

$n_{p3} = 2700 / (3*3.15) = 289.389$ rpm
 $v = \pi d n / 60 = 1.0450$ m/s
 $Y =$ Lewis Form Factor = 0.114
 $C_v =$ velocity factor = 0.851
 $B =$ face width = 30
 $P_c =$ pitch circle diameter = 9.424

$W_T = \sigma * c_v * b * p_c * y$
 $W_T = 7314.17$
 Power, $p = 7.6$ kW

Note: - Above value of power is larger than the maximum power we are going to transmit which is 7.6kw. Hence the design is safe.

5.4 Gear Specifications

Table-2: Gear specifications chart

| | GEAR 1 | GEAR 2 | GEAR 3 | GEAR 4 |
|-------------------------------|--------|--------|--------|--------|
| No.of teeth | 20 | 63 | 23 | 72 |
| Module (mm) | 2.5 | 2.5 | 3 | 3 |
| PCD | 50 | 157.5 | 69 | 216 |
| Addendum circle diameter (mm) | 55 | 162.5 | 75 | 222 |
| Dedendum circle diameter (mm) | 43.75 | 151.2 | 61.55 | 208.5 |

5.5 Gear Design Validation

For the gear design validation, the finite element analysis (FEA) is being performed on Ansys 15.0 software. The software treats the whole entity in the small parts and the analysis is being done on each part such that collectively they are called as a mesh. Here the analysis is being performed by applying tangential load on the pinion gear as shown in fig.

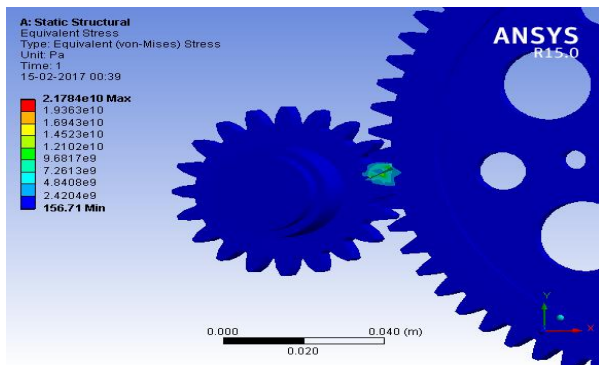

Fig- 5.5.1 Analysis of gear 1 and 2

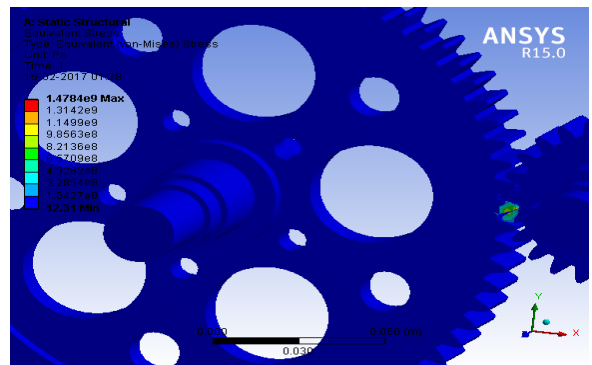

Fig-5.5.2 Analysis of gear 2 and 3

6. SHAFT DESIGN

A shaft is a cylindrical object composed of either same material as that of gear or different materials depending upon the objective of usage. The shafts ranging from 10mm to 2500mm can be manufactured according to the customers' needs. On the basis of rigidity or strength shaft is being designed. Designing a shaft on the basis of strength following factors are considered

- Shafts subjected to torque
- Shafts subjected to bending moment
- Shafts subjected to a combination of torque and bending moment
- Shafts subjected to axial loads

When the shaft is subjected to a combination of torque and bending moment, principal stresses are calculated and then different theories of failure are used. Bending stress and torsional shear stress can be calculated using the above relations.[6,7]

$$\tau = \frac{T r}{J} = \frac{T \frac{d}{2}}{\frac{\pi}{32} d^4} = \frac{16 T}{\pi d^3} \quad (3.8)$$

$$\sigma_b = \frac{M y}{I} = \frac{M \frac{d}{2}}{\frac{\pi}{64} d^4} = \frac{32 M}{\pi d^3} \quad (3.9)$$

$$\tau_{max.} = \sqrt{\left(\frac{\sigma_b}{2}\right)^2 + (\tau)^2} = \sqrt{\left(\frac{16 M}{\pi d^3}\right)^2 + \left(\frac{16 T}{\pi d^3}\right)^2} = \frac{16}{\pi d^3} \sqrt{M^2 + T^2} \leq [\tau] \quad (3.10)$$

Equation 3.10 shows us the maximum shear stress according to proposed shear stress theory. Now deflection in the shaft is proposed by eq.

$$EI \frac{d^2y}{dx^2} = Ra * x - 3061.6135(x - 74.5)$$

Table-3: Shaft Parameters

| Parameter | SHAFT 1 | SHAFT 2 | SHAFT 3 |
|--------------------|----------|------------|-------------|
| Diameter | 17mm | 25mm | 45mm |
| Deflection | 0.005mm | 0.0021mm | 0.0026mm |
| Angular deflection | 0.008rad | 0.0087 rad | 0.009695rad |

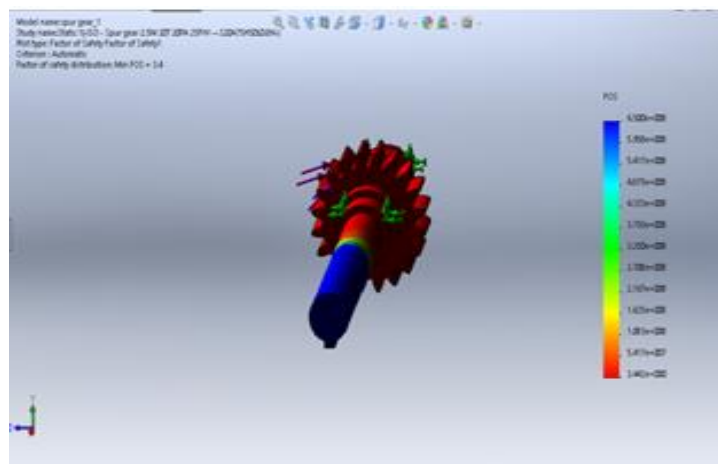

Fig-6.1 Analysis of shaft 1 on SolidWorks

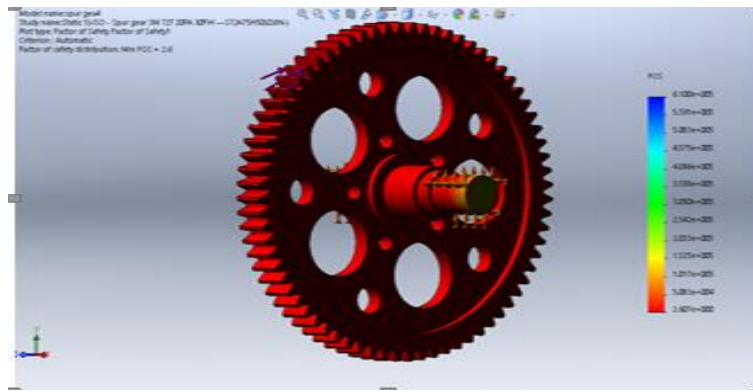

Fig-6.2 Analysis of shaft 4 on SolidWorks

7. BEARING SELECTION

Selection of bearing is based on the reliability. The criteria for selection is 90% reliability.

For following life: - [8]

(8 hours' operation per day)- 25000 hours.

7.1 Shaft 1 Bearing:

Since the axial load acting on the shaft are neglected and only radial forces are the primary concern for the gearbox gears functioning. $F_a = 0$. Therefore, the radial force acting on the gears is going to be divided into the two radial bearings and hence generating two reactions i.e. R_A & R_B .

At bearing A, $R_A = 1050N$. Now at bearing B, $R_B = 2020N$. Now axial thrust acting on the bearing $F_a = 0$. For designing a bearing choosing greater load, therefore $R_{max}(F_r) = 2020N$.

Equivalent Dynamic Load, $P_{eff} = X*V*F_r + Y*F_a$ [6,7]. F_r = Radial load. F_a = Axial load.

For Deep Groove Ball Bearing

$P_{eff} = X*V*F_r = 0.56*1*2020 = 1131.20N$ ($V = 1$, for inner race rotating)

Choose => Bearing No 6205

Dynamic load capacity, $C = 14.3 KN$. [6,7] Static load capacity, $C_0 = 7.8 KN$. [6,7]

For safety considerations $0.03*C < P < 0.1C$ i.e. $0.03*14300 < P < 0.1*14300$. $429 < P < 1430$. Now the P_{eff} lies in the safe region hence the bearing chosen is justified. Life of bearing = $(C/P)^a * 10^6 / (60*900) = 41536$ hours.

7.2 Shaft 2 Bearing:

Similarly, the bearing chosen for shaft 2 is 6206. $C_0 = 20.8KN$. [6,7] and $C = 11.2KN$. [6,7]

Hence bearing life is = 26400 hour.

7.3 Shaft 3 Bearing:

Similarly, the bearing chosen for shaft 3 is 6206 with a bearing life of 27000 hours.

8. CONCLUSION

Following conclusions can be drawn out:

- Center of gravity (CG) of any vehicle determines the overall vehicle performance. So keeping the CG of any vehicle as low as possible is desired. Acceleration, vibrations, and CG of the vehicle are highly affected by the engine placement.
- Gearbox designed are mainly single stage or two stage reduction ratio gearbox. But the problem with the single stage reduction is that to infer higher reduction ratio the size of it increases due to which the two-stage reduction gearbox is preferred.
- With the high-end materials such as AISI 4340, AISI 9130 & carbon fiber the overall weight of the gearbox can be reduced to a minimum such that for an ATV lighter weight with high performance is desirable.
- For the optimum design of the two-stage gearbox, the reduction ratio in two stages should somewhat equal due to which the casing drawn will symmetrical, similarly a Factor of Safety (FOS) of 2 is considered safe for designing.

9. REFERENCES

- [1] Fundamentals of Motor Vehicle Technology, (BOOK 2) by V.A.W. Hillier and David R. Rogers.
- [2] Fundamental of Vehicle Dynamics by Thomas D. Gillespie.
- [3] Automotive Transmissions by Herald Naunheimer, Bernd Bertsche, Joachim Ryborz and Wolfgang Novak.
- [4] Tudose, L. Buiga, O. Jucan D. Stefan ache, C. Optimal Design Of Two Stage Speed Reducer, MACMESE, Romania (74-79),2008.

- [5] MATERIAL SELECTION IN GEAR DESIGN Radinko Gligorijević, Jeremija Jevtić, Djuro Borak
- [6] A Textbook of Machine Design by R. S. Khurmi and J.K. Gupta.
- [7] Design Data Handbook by K. Mahadevan and K. Balaveera Reddy.
- [8] SKF bearing catalog.